

# 5 DAYS TO THE BIOLOGY EOCT Student Edition



**Glencoe  
McGraw-Hill**

New York, New York   Columbus, Ohio   Woodland Hills, California   Peoria, Illinois





This booklet was written by The Princeton Review, the nation’s leader in test preparation. The Princeton Review helps millions of students every year prepare for standardized assessments of all kinds. Through its association with Glencoe/McGraw-Hill, The Princeton Review offers the best way to help students excel on the Biology EOCT.

The Princeton Review is not affiliated with Princeton University or Educational Testing Service.

# CONTENTS

Introduction .....1

Day 1 .....2

Days 2 and 3 .....16

Important Vocabulary and Concepts Chart .....17

Days 4 and 5 .....20

Practice Test .....21

**Glencoe/McGraw-Hill**



*A Division of The McGraw-Hill Companies*

Copyright © The McGraw-Hill Companies, Inc. All rights reserved. Permission is granted to reproduce material contained herein on the condition that such material be reproduced only for classroom use; and be provided to students, teachers, and families without charge. Any other reproduction, for use or sale, is prohibited without written permission of the publisher.

Send all inquiries to:  
 Glencoe/McGraw-Hill  
 8787 Orion Place  
 Columbus, OH 43240-4027

ISBN 0-07-827718-3

Printed in the United States of America

1 2 3 4 5 6 7 8 9 10 024 08 07 06 05 04 03 02 01

# INTRODUCTION

## WELCOME TO 5 DAYS TO THE BIOLOGY EOCT!

This workbook is designed to help you prepare for the Biology End of Course Test (EOCT). Throughout this year, you have studied the important concepts and vocabulary needed to demonstrate a basic understanding of biology. Over the next five days, you will review what you have learned, familiarize yourself with key test-taking strategies, and take a practice test. Keep in mind that this workbook is designed to help prepare you for the test and should not be used as a substitute for other types of review. To prepare fully for the test, you should also study your textbook and notes and attend any review sessions your teacher conducts. The following breakdown describes the five-day program of this workbook:

- Day 1:** Learn general test-taking techniques and specific strategies for answering the different types of questions on the test.
- Days 2–3:** Working in groups, fill out the chart of important vocabulary and major concepts. Then review this chart to determine which topics require additional study.
- Day 4:** Take a full-length practice test similar to the Biology EOCT.
- Day 5:** Review the practice test to determine your areas of strength and weakness.

## TEST-TAKING STRATEGIES

There is more to taking the Biology EOCT than just recalling material from your textbooks. To be fully prepared for the test, learn and practice the following test-taking techniques. These strategies will help you make educated guesses, avoid making careless mistakes, and ensure that you do your best.

- **Use the process of elimination.** This is the best strategy for approaching any multiple-choice question. To answer difficult questions, read each answer choice and cross off the ones that you know are incorrect. Then choose from the remaining answer choices. Using the process of elimination greatly increases your chances of answering questions correctly. See page 3 in this workbook for more information.
- **Read carefully.** Make sure you understand the question being asked completely. This may involve reading the question over several times. Carefully study any graphics that are included with the questions. In addition, make sure to read each answer choice of a multiple-choice question *before* you choose an answer.
- **Prioritize.** If you cannot answer a question, mark it and try to return to it later. Move on to the questions you are able to answer. You may find that as you answer other questions on the test, you are reminded of a concept that will help you answer a skipped question. *Be careful when you skip a question!* Make sure to leave a blank space on your answer sheet for that question. And don't forget to go back and make your best educated guess. Questions left unanswered are marked as incorrect, so you should always supply an answer for every question, even if you have to guess.
- **Review your work.** Once you have answered all of the questions, go back and review your answers. Double-check your answers and computations. Use as much time as you need to prevent losing points because of careless errors.

Name:

Date:

## USING THE PROCESS OF ELIMINATION

The most useful technique for answering a multiple-choice question is the **process of elimination**. A multiple-choice question gives you four answer choices from which to choose, and only *one* of the choices is the best answer. Figuring out which three answer choices are *incorrect* is just as important as figuring out which one answer choice is *correct*. If you are able to eliminate only one or two of the answer choices, you have still greatly increased your chances of choosing the correct answer, even if you end up having to guess from the remaining choices. Always use the process of elimination when answering any multiple-choice question to which you do not immediately know the correct answer.

Here's an example.

Imagine that you are a contestant on a game show. The host asks you the question "What is the capital of the country of Nepal?" If you answer correctly, you will win \$1 million. You are given the following four possible answer choices:

- A. Tokyo
- B. Cairo
- C. Beijing
- D. Kathmandu

Do you know the capital of Nepal? Even if you don't, you can still win the money! Use the process of elimination. First, get rid of the answer choices that you know are wrong. Next, choose from the remaining choices. The fewer the answer choices you have to choose from, the better chance you have of picking the correct answer!

Let's see how it works. Which of the cities above do you know are *not* the capital of Nepal? You may know that *Tokyo* is the capital of Japan, *Cairo* is the capital of Egypt, and *Beijing* is the capital of China, so those cannot be correct answers. That leaves you with only *Kathmandu*. Kathmandu must be the capital of Nepal! Even if you did not know the capital of Nepal right away, the process of elimination made you a millionaire!

Use the **process of elimination** to find the best answer on any multiple-choice question.

1. Read each answer choice, one by one.
2. Get rid of the answer choices you *know* are wrong by putting a slash mark through their letters.
3. Save the answer choices that might be correct or that you are not sure about.
4. Choose an answer choice from the ones you think might be correct. If you do not know the answer, take your best guess.

Let's use the process of elimination to find the answer to a question about biology. The question below resembles one you might see on the Biology EOCT.

- ▶ 1. Which of the following is made up of two complementary chains of nucleotides?
- A. ADP
  - B. ATP
  - C. DNA
  - D. RNA

Read the question carefully. Note the key scientific terms in the question, e.g., *complementary* and *nucleotides*. Now read each answer choice and eliminate the ones that you know are wrong.

Adenosine diphosphate (ADP) is a complex molecule, but it is not made up of two complementary chains. Therefore, you can eliminate (A). Similarly, you can rule out (B) because adenosine triphosphate (ATP) differs from ADP merely by having a third phosphate group. Deoxyribonucleic acid (DNA) is made up of two complementary chains of nucleotides, so (C) looks like a good candidate for the correct answer. Ribonucleic acid (RNA), although it is made up of a chain of nucleotides, is a single-stranded molecule. Therefore, you can get rid of (D). By the process of elimination, you can determine that (C) is the correct answer.

Now try to answer the next question using the process of elimination.

- ▶ 2. Which type of organism is an exception to cell theory?
- A. bacterium
  - B. fungus
  - C. protozoan
  - D. virus

Read the question carefully. Recall what you have learned about cell theory. Then consider each answer choice, one by one, and eliminate the ones that you know are incorrect. **Hint:** Which type of organism consists of either DNA or RNA inside a protein shell? If you know, you will discover that the correct answer choice is (D).

## FACT QUESTIONS

Certain questions on the Biology EOCT assess your knowledge of biological facts and terminology. It is very important that you understand what is being asked before answering a question, so read the question as many times as is needed. Sometimes, you will simply need to recall factual information in order to answer the question. Other times, you will need to apply this factual information to a new situation or a more complex problem.

► 1. Protein synthesis occurs in which of the following cell organelles?

- A. chloroplasts
- B. mitochondria
- C. nucleus
- D. ribosomes

Read the question carefully. Note the use of terms such as *protein synthesis* and *organelles*. If you are not familiar with the meanings of these words, use the process of elimination to get rid of the answer choices you know are wrong. Then choose the best answer choice from the ones that remain.

This question tests your knowledge of the parts of the cell and their functions. You need to recall facts that you learned about cell organelles (cell components that perform specific functions). *Chloroplasts* are the site of photosynthesis, so you can eliminate answer choice (A). *Mitochondria* are organelles involved in cellular respiration, so you can eliminate (B). The *nucleus* is involved in DNA replication and transcription, so you can eliminate (C). That leaves (D), *ribosomes*, as the only possible correct answer choice.

Of course, it is difficult to eliminate choices if you are not able to recall the names of cell organelles and their functions. That is why it is important to review vocabulary before you take the test.

## CAUSE-AND-EFFECT QUESTIONS

Some questions on the Biology EOCT assess your understanding of cause-and-effect relationships. This is an important skill, particularly in science. The purpose of any scientific investigation is to observe phenomena in nature and try to determine what causes them to occur.

Some questions describe the effects of a certain procedure and then ask you to identify the cause. Other questions describe a procedure designed to cause a change and then ask you to predict the effects. Sometimes you need to determine the causes or effects of a procedure using your scientific knowledge and experience. Other questions may ask you to determine causes or effects based on data contained in a chart, table, or graph. Cause-and-effect questions usually contain key words such as *why*, *how*, *reason*, *because*, *effects*, *affect*, and *change*. Look for these words as you read the questions on the test.

The following question resembles one you might see on the Biology EOCT.

- ▶ 1. **Harmful gases produced by the burning of fossil fuels combine with moisture in the air to form acid rain. Which of these strategies would reduce the production of acid rain?**
- A. improving weather forecasting
  - B. introducing new fish into lakes and streams
  - C. decreasing the amount of moisture in the air
  - D. filtering out harmful gases before they enter the air

Read the question carefully. In this case, the word *reduce* indicates a desired kind of change. You are asked to determine which strategy would cause a reduction in the amount of acid rain produced (effect). The question tells you that “harmful gases . . . combine with moisture in the air.” The ability to forecast the weather will not affect this process, so you can eliminate answer choice **(A)**. New species of fish will not affect the amount of acid rain, so you can eliminate **(B)**. Scientists have not yet figured out how to deliberately change weather conditions, so you can eliminate **(C)**. That leaves **(D)** as the only possible correct answer choice. In fact, many power plants and factories use anti-pollution devices called “scrubbers” to trap gaseous emissions and reduce the amount of harmful gases entering the atmosphere.



Name:

Date:

## DRAWING CONCLUSIONS

Some questions require you to draw conclusions from the information provided in the question. In some cases, you must choose the best explanation for specific phenomena based on your knowledge of scientific principles and theories. Always read the information you are given carefully and use your common sense.

The following question resembles one you might see on the Biology EOCT.

- ▶ 1. A scientist conducted a study of algae in a pond. She observed that on clear days, algae could be found between one and six meters below the surface of the water. On cloudy days, however, algae could be found no more than one meter below the surface. What might the scientist conclude from these observations?
- A. Light intensity affects the depth at which algae grow.
  - B. Moisture in the air affects the depth at which algae grow.
  - C. Rainfall affects the depth at which algae grow.
  - D. Wind direction affects the depth at which algae grow.

Read the question carefully. In order to determine the correct answer, you must draw upon your knowledge of photosynthesis in algae. You must also use common sense in deciding what would affect the depth at which algae grow on clear days as opposed to cloudy days. Certainly light intensity would be different, and that would affect the growth of algae because they need sunlight to carry out photosynthesis. Thus, (A) is a good candidate for the correct answer. Moisture in the air may vary, but that should not affect the growth of algae, since they grow underwater. The same is true of rainfall and wind direction. Therefore, you can eliminate (B), (C), and (D). Notice how you had to interpret the information given in the question in order to form a conclusion.

## READING PUNNETT SQUARES

Some questions on the Biology EOCT ask you to interpret Punnett squares. A Punnett square is a diagram used to predict the probability that a certain genetic trait will appear in offspring. You have learned in class that a dominant gene completely masks the presence of a recessive gene. In a Punnett square, a capital letter signifies the dominant gene, while a lowercase letter signifies the recessive gene. The gene pairs of the parents are listed on the top and left sides of the Punnett square. One gene is taken from each parent to fill in the four smaller squares. The possible gene combinations in offspring are shown in the four smaller squares.

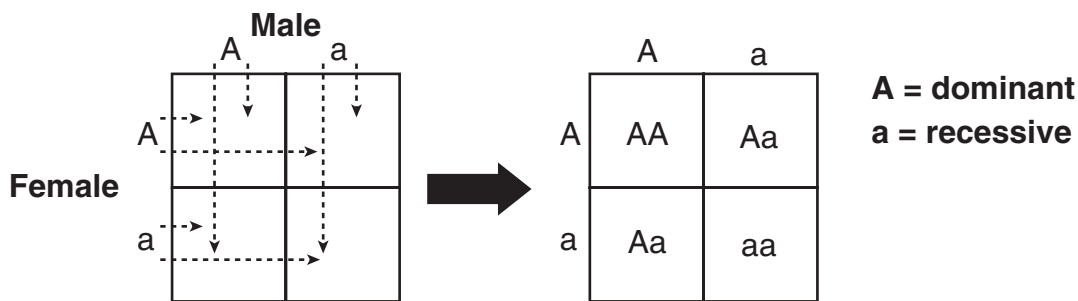

Punnett squares can be used to predict the ratio of phenotypes and genotypes that can be expected to appear in offspring. In some questions, the genotype of the offspring will be given and you will be asked to work backward to determine the genotype of the parents. In the above example, the ratio of genotypes in the offspring is 1:2:1 (one AA, two Aa, and one aa). Because A is dominant over a, the ratio of phenotypes is 3:1 (three dominant, one recessive). The dominant trait should appear in 75% (three out of four) of the offspring. Remember that these are only probabilities. The actual appearance of a particular offspring cannot be predicted with 100% certainty. Try the question on the next page.

Name:

Date:

Use the diagram below to answer the question.

	B	b
b	Bb	bb
b	Bb	bb

- ▶ 1. In rats, black fur (B) is dominant over white fur (b). In this cross between a hybrid black rat and a white rat, what percentage of the offspring will probably have black fur?
- A. 25%
  - B. 50%
  - C. 75%
  - D. 100%

Read the question carefully and examine the Punnett square. Use your knowledge of genetics to predict the phenotype of the offspring. Fifty percent of the offspring will probably be black (Bb) because black fur is dominant over white fur. Fifty percent will likely be white (bb). Therefore, the correct answer is **(B)**.

## READING CHARTS AND GRAPHS

Some questions on the Biology EOCT require you to read a graph to answer a question. You may be asked to locate a value that is specified by the question, or you may be asked to draw a conclusion from the graph. When answering these questions, study the graph carefully to determine the type of information that is provided.

**Read the paragraph, study the graph, and then answer the question that follows.**

A group of students performed an experiment to study the effects of glucose ingestion on the concentration of glucose in the blood. A blood sample was taken from an animal that had not eaten for twelve hours. The animal was then fed 20-mL of a glucose solution. Five more blood samples were taken at thirty-minute intervals following ingestion of the solution. The blood glucose concentration was determined for all samples. The results are plotted on the graph below.

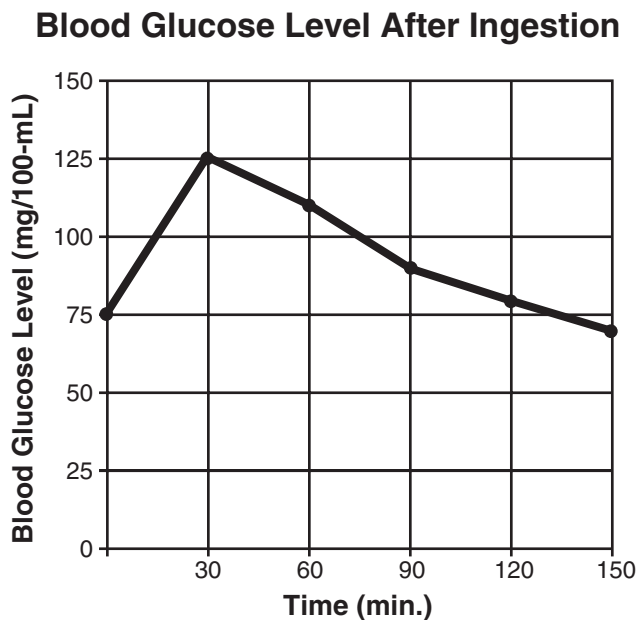

- ▶ 1. Following the ingestion of the glucose solution, how long did it take for the animal's blood glucose level to return to the point at which it started?
- A. 30 min.
  - B. 90 min.
  - C. 120 min.
  - D. 135 min.

Name:

Date:

Read the paragraph and then study the graph. Make sure you understand the information presented in the graph. Read the question carefully and then ask yourself what information you need to find the correct answer. Refer to the graph to find this information.

To determine the correct answer, you must know the animal's blood glucose level **prior to** the ingestion of the glucose solution. You can obtain this information from the graph. Locate 0-min. on the horizontal axis. Move up the 0-min. line until you reach the heavy, dark line that connects the points plotted on the graph. Move to the left to read the blood glucose level on the vertical axis. The starting level was 75-mg/100-mL.

Finally, you must determine how many minutes passed before the blood glucose level returned to this starting level. You can obtain this information from the graph as well. Locate 75-mg on the vertical axis. Move across the 75-mg line until you find the point at which the 75-mg line intersects the heavy, dark line. Then move straight down to the horizontal axis and determine the time. Since the point leads you midway between the 120-minute and 150-minute lines, you can estimate that approximately 135 minute passed before the animal's blood glucose level returned to the starting level of 75-mg/100-mL. Therefore, the correct answer is **(D)**.

Let's try another question that requires you to read and interpret a chart or graph.

Use the table below to answer the following question.

**Threatened Species in South America**

	Ecuador	Colombia	Paraguay
<b>Mammals</b>	28	35	10
<b>Birds</b>	53	64	26
<b>Reptiles</b>	12	15	3
<b>Amphibians</b>	0	0	0
<b>Fish</b>	1	5	0
<b>Total</b>	94	119	39

► 2. Which of these statements is best supported by the data in the table?

- A. There are about an equal number of endangered species in each country.
- B. There are no amphibian species living in South America.
- C. Birds are endangered because mammals eat them.
- D. Colombia has the greatest number of threatened species.

Read the question and then study the table carefully. Then consider each answer choice. Use the process of elimination to discount the ones that you know are wrong. You can conclude that **(D)** is the correct answer.

## USING DIAGRAMS

Some questions on the Biology EOCT may provide diagrams or visuals for you to interpret. A diagram may serve as a tool to help illustrate a question. In other cases, crucial information needed to answer a question correctly may be included within a diagram. Be sure to examine every diagram closely. The answer may be sitting right before your eyes!

Refer to the diagrams below to answer the following question.

A

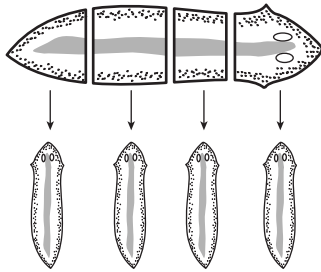

C

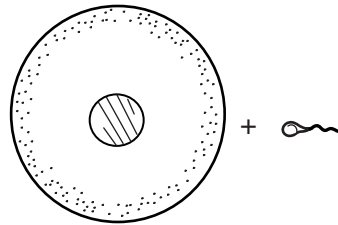

B

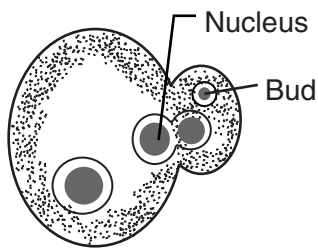

D



- 1. Which method of reproduction will produce the greatest variation in offspring?
- A. A
  - B. B
  - C. C
  - D. D

Name:

Date:

Read the question carefully and then examine each of the answer choices. The question asks about variation in offspring. What methods of reproduction are represented in the answer choices? Asexual reproduction (reproduction involving only one parent) is shown in **(A)**, **(B)**, and **(D)**. Barring environmental factors, the offspring resulting from asexual reproduction will be exactly like the parent because the genes of the offspring are identical to the genes of the parent. Therefore, there would be little or no variation in offspring. Sexual reproduction (reproduction involving two parents) is shown in **(C)**. Because sexual reproduction provides for the combining of genetic material from both parents, an infinite number of gene combinations is possible. This would result in the greatest variation in offspring. Thus, **(C)** is the correct answer.

## MAKING PREDICTIONS

Some questions on the Biology EOCT ask you to predict outcomes based on information provided in the questions. The questions outline a set of conditions and then ask you to predict the most likely results. You can make these predictions by applying your knowledge of scientific concepts and laws to the given situation. Try the following questions.

- ▶ 1. In a certain plant, purple flowers (P) are dominant over white flowers (p). Two hybrid parent plants produce 600 offspring. About how many of the offspring should have white flowers?
- A. 150
  - B. 300
  - C. 450
  - D. 600

Read the question carefully. The question outlines certain conditions: purple (P) is dominant over white (p), and both parents are hybrids (Pp). If you set up a Punnett square for this cross, you will discover a genotypic ratio of 1PP:2Pp:1pp and a phenotypic ratio of three purple to every one white. Because one out of every four plants should have white flowers, the correct answer is 1/4 times 600, or 150. By analyzing the conditions specified and using your scientific knowledge, you are able to predict the outcome, answer choice (A).

- ▶ 2. A mouse skin cell contains 40 chromosomes. Based on this information, how many chromosomes would a mouse sperm cell contain?
- A. 10
  - B. 20
  - C. 40
  - D. 80

**Hint:** What type of cell division produces sperm cells? If you know, you will discover that the correct answer is (B).



Name:

Date:

## SEQUENCING AND CATEGORIZING

Some questions on the Biology EOCT ask you to put things in sequence or in categories. Sequencing requires you to arrange a list of objects or events in a specific order. The order may be chronological (according to the time events occurred), hierarchical (from largest to smallest), or from most inclusive to least inclusive. To form a sequence, you must be able to recognize relationships between objects or events and categorize them. Let's look at a chronological sequence.

- 1. Some of the major events in cell biology are listed below. Which answer choice lists the events in the order in which they occurred?

1 - Schleiden and Schwann propose the cell theory.

2 - Leeuwenhoek discovers bacteria.

3 - Ruska builds the first electron microscope.

4 - Hooke coins the word "cell" to describe microscopic observations of cork.

- A. 2, 4, 1, 3  
 B. 3, 1, 2, 4  
 C. 4, 1, 2, 3  
 D. 4, 2, 1, 3

Read the question carefully. It asks you to list events in chronological order. Even if you are not familiar with the names of the scientists, you should be able to recognize that the most recent event must be 3—the building of an electron microscope—because of the technology involved.

Therefore, you can eliminate **(B)**. Now notice that the remaining answer choices differ only in their sequencing of event number 2. How is the discovery of bacteria related to events 1 and 4? You may have learned that bacteria are much smaller than plant or animal cells and were probably discovered some time after cells were first observed. Therefore, eliminate **(A)**. Moreover, common sense dictates that before you can propose a cell theory, you must first observe many different cells of all sizes, including bacteria. The correct answer, then, is **(D)**. Let's try a hierarchical sequence.

- 2. In order from smallest to largest, the levels of organization in the human body are

- A. cells, tissue, organs, systems, organism.  
 B. cells, tissue, organism, systems, organs.  
 C. tissue, cells, systems, organs, organism.  
 D. organism, organs, systems, tissue, cells.

**Hint:** What makes up a system? What makes up an organ? What makes up a tissue? If you know, you will discover that the correct answer is **(A)**.

## DAY 2

### IMPORTANT VOCABULARY AND CONCEPTS

During the course of this year, you have studied a wide variety of topics in science. As part of your studies, you have learned many new, important scientific terms and concepts. For instance, did you know what a heterotroph was before this year? Had you ever heard of mitosis?

In preparation for the Biology EOCT, you should review the important scientific terms and concepts that you have learned. Use the chart on pages 17–19 to refresh your memory and to prepare for the test.

During Day 2, form a small group with some of your classmates and work together to fill out the chart. For each term or concept, first fill in the definition. You may find it helpful to look up many of these terms and concepts in your Glencoe textbook. Even if you know a definition, refer to your textbook to double-check it.

Once this chart is completed, use it as a study guide. Pay particular attention to the words you did not immediately recognize or could not define. This will help you identify the topics that you should spend extra time reviewing.

## DAY 3

### REVIEW IMPORTANT VOCABULARY AND CONCEPTS

On Day 3 you will review the entire chart with your teacher and class. Make sure you have listed the correct definition for each term and concept. In addition, make sure to add any terms or concepts that your classmates contribute. **Remember:** Mark down any words that are unfamiliar to you and be sure to spend extra time reviewing them. Spending time familiarizing yourself with all the vocabulary and concepts in the chart will help to prepare you for the test.

Name: \_\_\_\_\_

Date: \_\_\_\_\_

## IMPORTANT VOCABULARY AND CONCEPTS

VOCABULARY AND CONCEPTS	DEFINITION
<b>Animals</b>	
Homeostasis	
Invertebrate	
Vertebrate	
<b>Cells</b>	
Active transport	
Cell wall	
Chloroplast	
Diffusion	
Endoplasmic reticulum	
Mitochondrion	
Nucleus	
Organelle	
Osmosis	
Ribosome	
Vacuole	
<b>Classification</b>	
Binomial	
Class	
Eukaryote	
Genus	
Kingdom	
Order	
Phylum	
Prokaryote	
Species	

VOCABULARY AND CONCEPTS	DEFINITION
<b>Ecology</b>	
Abiotic factors	
Adaptation	
Autotroph	
Biome	
Biotic factors	
Decomposer	
Ecosystem	
Food chain	
Food web	
Habitat	
Heterotroph	
Parasitism	
Population	
<b>Plants</b>	
Cellular respiration	
Guard cell	
Phloem	
Photosynthesis	
Pistil	
Pollination	
Stamen	
Stoma	
Transpiration	
Vascular	
Xylem	

Name:

Date:

VOCABULARY AND CONCEPTS	DEFINITION
<b>Genetics</b>	
Allele	
Chromosome	
Crossing over	
Diploid	
DNA replication	
Dominant	
Gamete	
Gene	
Genotype	
Haploid	
Heterozygous	
Homozygous	
Hybrid	
Meiosis	
Mitosis	
Mutation	
Nondisjunction	
Phenotype	
Recessive	
Trait	

# DAY 4

## TAKING THE PRACTICE TEST

On Day 4 you will take the practice test in this workbook. This test has been designed to resemble the Biology EOCT. To better acquaint you with the test, this practice test has the same number of multiple-choice questions as does the actual test.

To receive the most benefit from this practice test, treat it as you will treat the real test. Read the questions carefully, answer them using strategies such as the process of elimination, and check your work. This way, you can get a good sense of your performance on the actual test.

Your teacher will provide you with answer sheets. All of your answers must appear on these sheets. Be sure to mark only one answer for each question.

# DAY 5

## REVIEWING THE PRACTICE TEST

On Day 5 your teacher will review the correct answers to the test. Make sure that you understand the rationale behind each correct answer and pay special attention to the questions you answered incorrectly. Take time to review vocabulary and concepts related to the questions that you got wrong. Did you notice any particular areas of biology that you need to study further? If so, spend time concentrating on those topics and then go back and review the subjects you think you know well.

While taking the practice test, did you remember to use the test-taking strategies you learned in this book? Did you read all of the questions and instructions carefully? Did you prioritize? Did you remember to go back and answer all of the questions that you initially left blank? Did you pace yourself, remembering not to spend too much time and energy on any one question?

Finally, consider your performance overall. How did you feel when taking the test? Did you take your time and review your work? Were you able to answer all of the questions, even the ones about which you were unsure? Answer these questions honestly and try to think of ways you can improve your performance as you continue preparing for the Biology EOCT.

Name:

Date:

1.

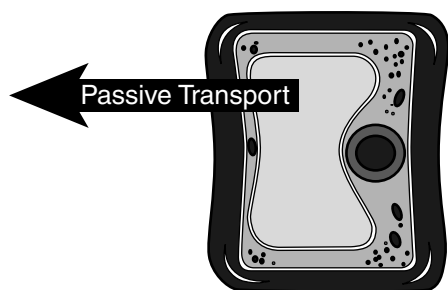

In the diagram above, the concentration of ions and molecules outside the cell is **most** likely

- A. twice as high as the concentration of ions and molecules inside the cell.
- B. the same as the concentration of ions and molecules inside the cell.
- C. lower than the concentration of ions and molecules inside the cell.
- D. composed of a different variety of ions and molecules than is inside the cell.

2. A medical laboratory conducted an experiment to see if caffeine consumption has an effect on memory. In one afternoon, participants were asked to drink two cups of coffee each hour for four hours, to review a sequence of ten pictures, and then to remember each picture. Which of these is the dependent variable in this experiment?

- A. the amount of caffeine in each cup of coffee
- B. the number of pictures remembered by each participant
- C. the amount of coffee each cup holds
- D. the number of participants

3. A researcher is studying Solution A, a body fluid that contains 0.8% sodium. Which of these solutions containing sodium is hypertonic to Solution A?

- A. 0.8%
- B. 0.5%
- C. 0.7%
- D. 1.8%

4. Alligators in wetland regions normally feed on animals such as shorebirds. Shorebirds usually feed on small fish and frogs to survive. Recently, scientists released a large number of alligators into a wetland region. Scientists expect that as a result of this increase in the alligator population, the population of small fish and frogs will

- A. remain about the same.
- B. rapidly decrease.
- C. become extinct.
- D. notably increase.

5. A student collects seashells from a beach while on vacation. The animals that once inhabited these shells **most** likely belonged to which of the following classes of the animal kingdom?
- A. Osteichthyes
  - B. Echinoidea
  - C. Bivalvia
  - D. Arachnida
6. Which of these is **not** associated with proteins?
- A. amino acid
  - B. enzyme
  - C. polysaccharide
  - D. peptide bond
7. Some humans can roll their tongues, while others cannot. Simple dominant traits, such as tongue rolling, are determined in humans by
- A. cleaved DNA.
  - B. a point mutation on the X chromosome from the mother only.
  - C. dominant alleles from the father only.
  - D. dominant alleles from either the father or the mother, or both.
8. What is the classification for the deciduous forests of the northeastern United States?
- A. taiga
  - B. temperate forests
  - C. tropical rain forests
  - D. tundra
9. In humans, the gene for normal vision (C) is dominant to the gene for color blindness (c). Color blindness is a sex-linked trait. Which of the following would be the genotype for a colorblind male?
- A.  $X^CY$
  - B.  $X^cY$
  - C.  $X^CX^c$
  - D.  $X^cX^c$
10. If farmers wish to decrease the mouse population in a farm, what would be the **best** way to do this?
- A. Introduce another variety of mice to compete for resources.
  - B. Introduce more animals that prey on mice.
  - C. Decrease the number of producers on the farm.
  - D. Introduce more parasites onto the farm.



Name:

Date:

11. Mendel discovered that in pea plants, the allele for tall plants (T) is dominant to the allele for short plants (t). If a homozygous tall pea plant is crossed with a homozygous short pea plant, what will be the genotypes of the offspring?
- A. Tt only
  - B. Tt and TT only
  - C. TT and tt only
  - D. TT only
12. The sorting and organization of proteins occurs in which part of a cell?
- A. mitochondria
  - B. vacuoles
  - C. Golgi apparatus
  - D. endoplasmic reticulum
13. Certain animals, such as elephants, reproduce at a slow rate and produce few offspring over the course of their lives. Why do these animals produce few offspring?
- A. Every offspring will live long enough to reproduce.
  - B. Certain animal populations are decreasing around the world.
  - C. The females are only fertile once over the course of their lives.
  - D. Many of the offspring will reach maturity.
14. Which of these represents a parasitic relationship?
- A. plankton on a whale
  - B. a tick on a dog
  - C. Spanish moss on a tree
  - D. a shark eating a fish
15. Malpighian tubules and nephridia are structures found in certain invertebrates. What is their function?
- A. to collect wastes
  - B. to synthesize proteins
  - C. to transmit nerve impulses
  - D. to transport oxygen
16. RNA is essential for the building of proteins. Which of these is **not** a type of RNA?
- A. messenger RNA
  - B. mitochondrial RNA
  - C. transfer RNA
  - D. ribosomal RNA

17. Which of the following would be the **least** reliable evidence in determining whether or not two animals share a taxonomic relationship?
- A. physical structures and appearance
  - B. appearance of chromosomes
  - C. diet and nutrition
  - D. DNA sequences
18. Tundra is a biome that mostly is found near the
- A. south pole.
  - B. equator.
  - C. north pole.
  - D. Antarctic Circle.
19. Producers primarily obtain their energy from
- A. nutrients in the soil.
  - B. the sun.
  - C. water.
  - D. decomposing organisms.
20. When plants reproduce, which process replicates their chromosomes?
- A. mitosis
  - B. fertilization
  - C. meiosis
  - D. pollination
21. Which of the following may **not** be observed using a modern light microscope?
- A. plant cell walls
  - B. red blood cells
  - C. DNA molecules
  - D. bacteria

Name: \_\_\_\_\_

Date: \_\_\_\_\_

22.

**HDL and LDL Cholesterol Levels**

	Subject 1	Subject 2	Subject 3	Subject 4
Sept.1	145	210	182	275
Oct.1	160	202	200	260
Nov.1	150	215	230	265
Dec.1	175	208	235	268
<b>Total</b>	812	822	860	886
<b>Average</b>	157.5	208.75	211.75	267

The chart above displays the blood HDL and LDL cholesterol levels of four men recorded on the first day of each month for four months. Which bar graph **best** represents the data in the chart?

**Tested Levels of HDL and LDL Cholesterol**

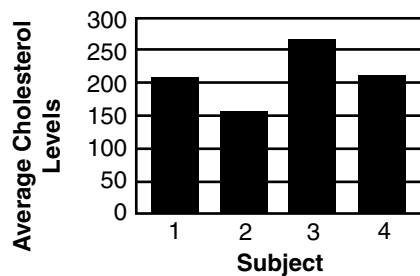

A.

**Tested Levels of HDL and LDL Cholesterol**

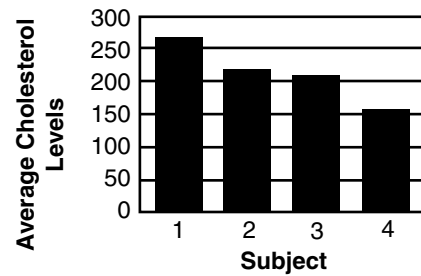

C.

**Tested Levels of HDL and LDL Cholesterol**

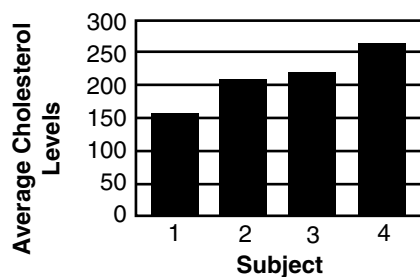

B.

**Tested Levels of HDL and LDL Cholesterol**

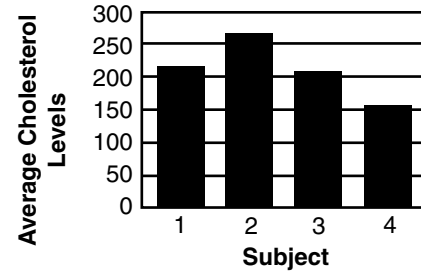

D.

23. What is the term for a molecule that combines with enzymes, undergoes a chemical reaction, and changes into new substance?

- A. peptide
- B. protein
- C. substrate
- D. nucleotide

24. Which of these plants does **not** use a vascular system to transport water?

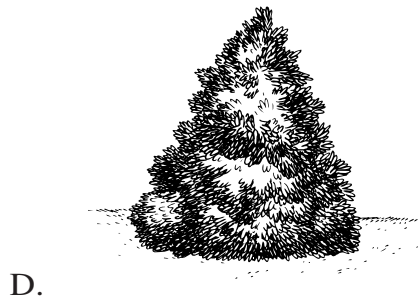
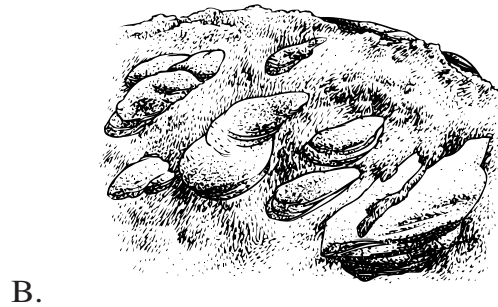
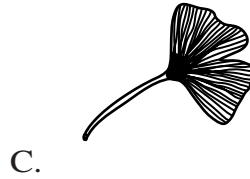

25. The starch that plants use for food storage is an example of a

- A. protein.
- B. polysaccharide.
- C. lipid.
- D. sucrose polymer.

26. A component of a marine biome may include a rocky shore just as a component of a freshwater biome may include

- A. a photic zone.
- B. an intertidal zone.
- C. an estuary.
- D. a lake.

Name:

Date:

27.

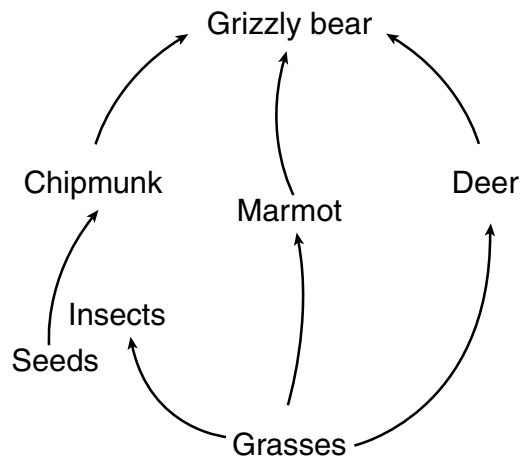

Which of these statements is **true** about the above food web?

- A. Grizzly bears have the highest biomass.
- B. Grasses have the lowest biomass.
- C. Deer have a higher biomass than grizzly bears.
- D. Seeds have a lower biomass than chipmunks.

28.

Two students are conducting a science experiment in which they need to heat a chemical in a test tube. The test tube contains a thermometer and the chemical. The teacher instructs the students to have one person operate the Bunsen burner while the other person observes the change in temperature of the chemical. Which of the following is the **best** thing for the students to do during this experiment?

- A. shake the test tube repeatedly
- B. clamp the test tube to the Bunsen burner
- C. make sure the test tube is not pointed toward anyone
- D. make sure the Bunsen burner produces a low flame

29.

The cell walls of plants are composed mainly of

- A. amino acids.
- B. nucleotides.
- C. cellulose.
- D. cytoplasm.

30.

Which of the following chemical reactions occurs when a cell creates energy?

- A. ATP creates more ATP
- B. ADP changes into ATP
- C. ADP creates more ADP
- D. ATP changes into ADP

31. **Population Growth of Species in an Ecosystem**

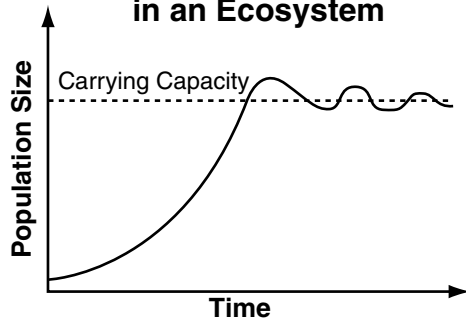

What does the line graph above show?

- A. Populations increase at a constant rate in ecosystems.
- B. Populations usually increase rapidly and then level off.
- C. Populations increase at an exponential rate.
- D. Ecosystems are able to support any number of populations.

32.

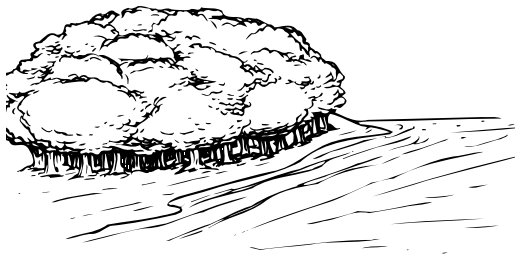

The first stage of succession of this forest was probably the growth of

- A. lichens.
- B. shrubs.
- C. mosses.
- D. trees.

33. In fruit flies, the gene for long wings is dominant to the gene for short wings. In order for a researcher to find out if a long-winged fruit fly is homozygous or heterozygous for long wings, the researcher should cross the long-winged fruit fly with

- A. a purebred, short-winged fruit fly.
- B. a purebred, long-winged fruit fly.
- C. a heterozygous, short-winged fruit fly.
- D. a heterozygous, long-winged fruit fly.



38. Which of the following classes of animals includes females that develop a hollow, muscular organ called the uterus?
- A. amphibians
  - B. invertebrates
  - C. mammals
  - D. reptiles
39. Why is the thyroid gland part of the human endocrine system?
- A. It is located in the neck near the parathyroid glands.
  - B. It releases hormones that control internal body functions.
  - C. It produces thyroxine and calcitonin.
  - D. It consists of two lobes, one on each side of the windpipe.
40. Plants that develop extensive root systems for absorbing water and have storage cells in their stems and roots would most likely be found in a
- A. tundra.
  - B. desert.
  - C. grassland.
  - D. temperate forest.
41. If the bacteria *Serratia marcescens* grows at 25°C, it is red in color. If it grows at 30°C, it is a cream color. What can be concluded from this example?
- A. Bacteria grow more rapidly at higher temperatures.
  - B. Environmental factors influence gene expression.
  - C. Bacteria reproduce more slowly at lower temperatures.
  - D. Different internal hormones are released at different temperatures.
42. What is the term for the role and position that a certain species of animal occupies in its environment?
- A. habitat
  - B. ecosystem
  - C. community
  - D. niche
43. What structures in plant cells capture light energy to produce food?
- A. chloroplasts
  - B. mitochondria
  - C. cilia
  - D. microfilaments



Name:

Date:

44. A human cell has 46 chromosomes. How many chromosomes will it have after the first mitotic division?

- A. 92 chromosomes
- B. 69 chromosomes
- C. 46 chromosomes
- D. 23 chromosomes

45. Mammals store food in their livers in the form of glycogen. Glycogen is a polymer composed of chains of

- A. starch.
- B. fructose.
- C. glucose.
- D. citric acid.

46.

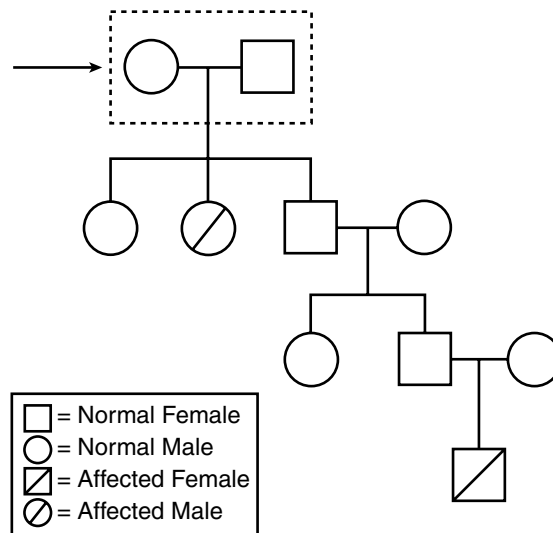

The pedigree above shows several generations. Which of the following does the arrow indicate?

- A. P1
- B. P2
- C. F1
- D. F2

47. A group of students conducted an experiment that required the use of chemicals. A student noticed that one of the beakers was leaking a chemical. What is the **first** thing the students should do?

- A. Check the other beakers for cracks.
- B. Cover the spilled chemical with sawdust.
- C. Alert their teacher to the leak.
- D. Get a new beaker to replace the one with the crack.

48. Which of the following is **not** associated with eukaryotes?

- A. nucleus
- B. organelles
- C. capsule
- D. multicellular

49.

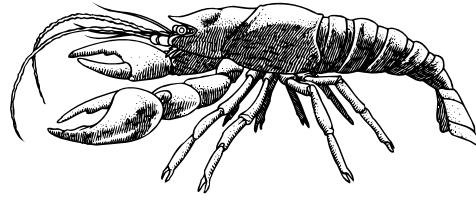

The above illustration shows an organism that is a member of the phylum

- A. Chordata.
- B. Mollusca.
- C. Arthropoda.
- D. Echinoderma.

50. If two organisms are able to reproduce successfully, they **must** be in the same

- A. genus.
- B. species.
- C. phylum.
- D. family.

Name:

Date:

51. The results of an experiment showed that as temperature increased, enzymatic activity increased to a maximum and then started to decrease. Which of these graphs correctly displays these findings?

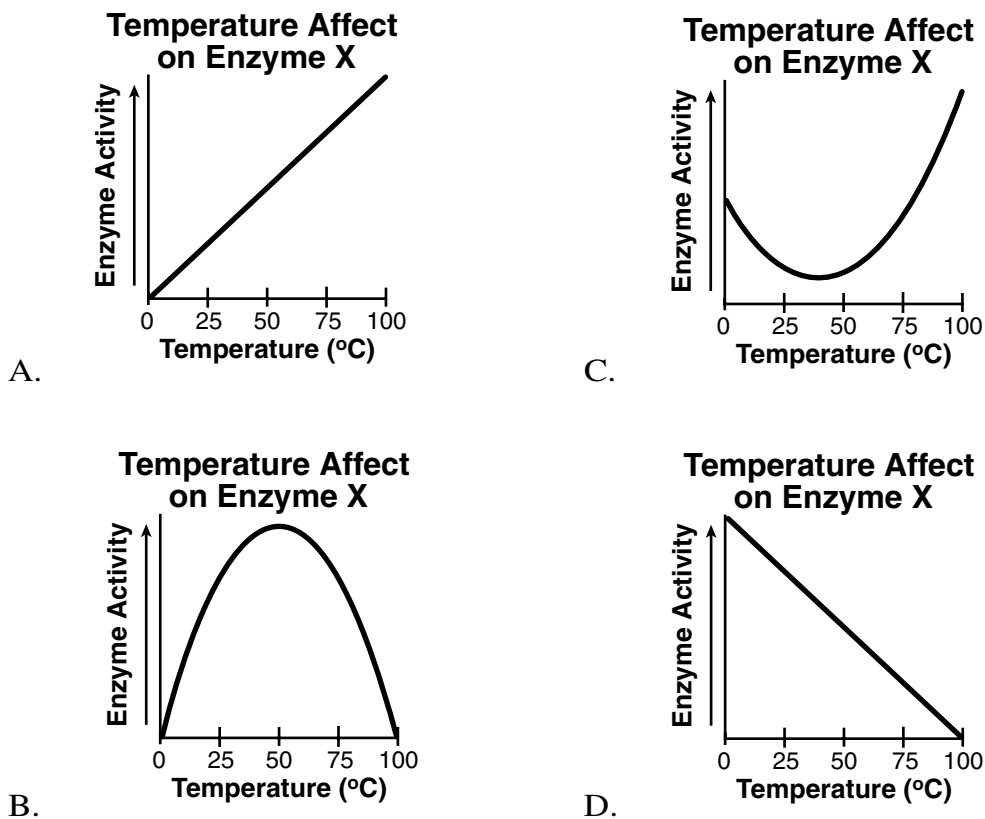

52. The element carbon is first introduced into an ecosystem by
- heterotrophs.
  - consumers.
  - autotrophs.
  - organisms with the lowest biomass.
53. When doing an experiment, it is important to follow all of these procedures **except**
- wearing protective goggles.
  - arranging and organizing the work space neatly.
  - understanding the meaning of the safety precautions.
  - using smaller beakers before using larger beakers.

**PRACTICE  
TEST**

Name:

Date:

54. Chromosomes are produced in what part of a eukaryotic cell?
- A. cell wall
  - B. nucleus
  - C. ribosomes
  - D. vacuole
55. Which of these is an example of smooth muscle?
- A. heart tissue
  - B. interior wall of stomach
  - C. biceps muscle
  - D. brain tissue
56. Which of the following is a way in which alcohol may affect the human body?
- A. It increases activity of the nervous system.
  - B. It heightens sensory perception.
  - C. It helps cells to reproduce.
  - D. It delays reaction time.
57. Most energy used in the human body is stored as
- A. proteins.
  - B. carbohydrates.
  - C. vitamins.
  - D. carbon.

Name:

Date:

58.

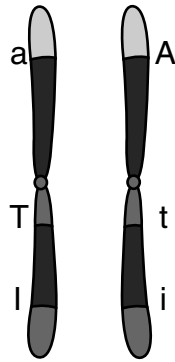

How would you **best** describe the chromosomes shown above?

- A. homologous
- B. homozygous
- C. chiasmatic
- D. trisomic

59.

	R	r		
R	RR	Rr	<b>Genotype</b>	<b>Phenotype</b>
			RR	Red
r	Rr	rr	Rr	Pink
			rr	White

A researcher crosses the F1 generation of two snapdragon plants. According to this information, what is the ratio of their offspring (F2)?

- A. 2 red: 1 pink: 1 white
  - B. 0 red: 4 pink: 0 white
  - C. 1 red: 2 pink: 1 white
  - D. 1 red: 1 pink: 2 white
60. While on a field trip, a student turned over a partially rotted log. The student observed fungi, termites, pill bugs, ants, slugs, and earthworms living in and around the log. Collectively, these organisms represent
- A. a community.
  - B. a habitat.
  - C. an environment.
  - D. a population.

61. Which nucleotide is the complementary strand of the nucleotide shown below?

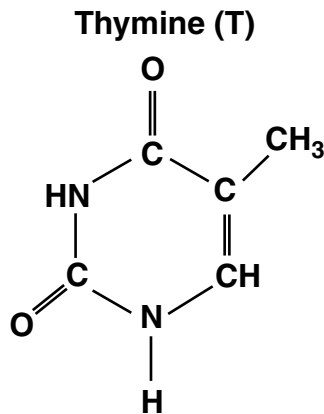

- A. adenine  
 B. guanine  
 C. cytosine  
 D. thymine
62. What causes the disease AIDS?
- A. HIV bacteria  
 B. HIV virus  
 C. HIV protozoa  
 D. HIV fungus
63. An increase in aquatic phytoplankton in an aquatic biome such as a swamp might be the **first** evidence that
- A. first-order heterotrophs have declined.  
 B. first trophic-level organisms have declined.  
 C. second-order heterotrophs have increased.  
 D. third-order heterotrophs have declined.

64. In humans, which part of the central nervous system coordinates motor activities and helps to maintain balance?

- A. cerebrum  
 B. cerebellum  
 C. medulla  
 D. spinal cord
65. What are algae and slime molds examples of?
- A. fungi  
 B. bacteria  
 C. protists  
 D. sporozoans

Name:

Date:

66.

**Exercise and Heart Rules**

Subject	Resting	Fast Walk	Slow Jog
1	65	72	110
2	78	88	120
3	72	83	125
4	69	78	105
5	75	90	135
<b>Averages</b>	71.8	82.2	119

This information was gathered during an experiment intended to test the relationship between heart rate and exercise. Pulses first were taken while participants rested and then immediately after participants walked quickly or jogged slowly for ten minutes.

Which of these statements **best** explains the data?

- A. There is no relationship between heart rate and exercise.
- B. Exercise increased the heart rate of some of the participants.
- C. Heart rate increased as exercise became more strenuous.
- D. Ten minutes of walking and jogging was not enough to cause any differences in heart rate.

67. Which of the following **best** represents an amino acid?

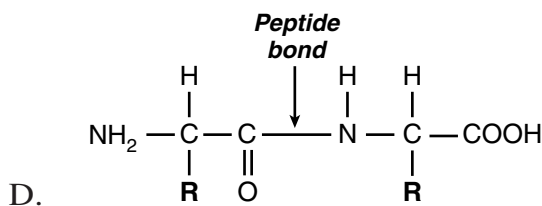
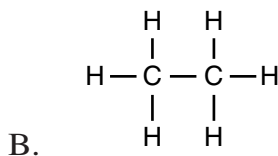
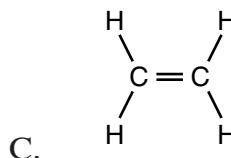
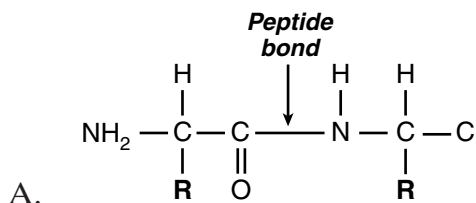

68. What are the membrane-bound structures that are found in eukaryotic cells called?

- A. organs
- B. cytoplasm
- C. organelles
- D. Golgi apparatus

69. Which of the following is the proper way to store a microscope?

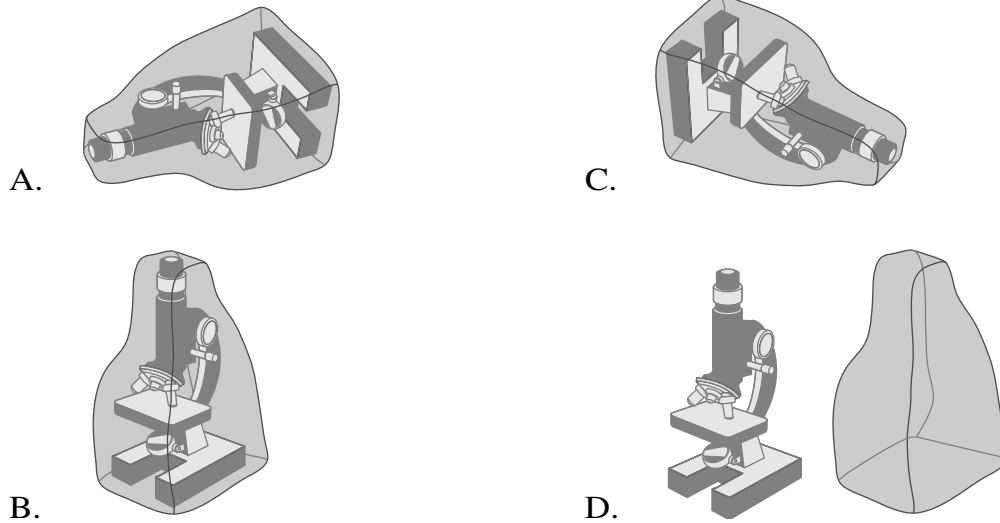

70. When a human egg is fertilized by a sperm, the zygote formed is a

- A. polyploid cell.
- B. triploid cell.
- C. diploid cell.
- D. haploid cell.



Name:

Date:

71.

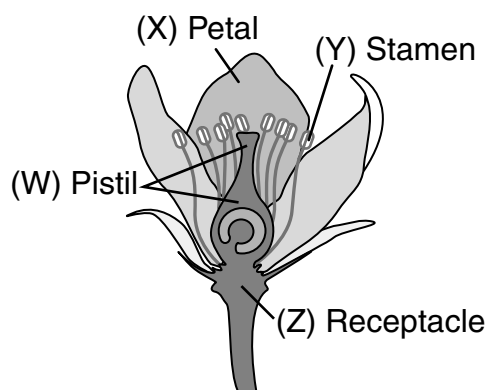

In the above diagram of a flower, the structure labeled with the letter “Y” helps the flower to

- A. transport water.
- B. absorb sunlight.
- C. reproduce.
- D. excrete waste.

72. Where does the energy that is transferred from animal to animal in a food chain ultimately come from?

- A. ocean tides
- B. the sun
- C. volcanoes
- D. plants

73. The pulp cells of apples contain 34 chromosomes. When these cells divide through the process of mitosis, how many chromosomes do they then contain?

- A. 17
- B. 27
- C. 34
- D. 68

74. As a result of strenuous exercise, muscles build up an excess of

- A. citric acid.
- B. lactic acid.
- C. oxygen.
- D. carbon monoxide.

75. In order to survive in its environment, a certain type of animal has evolved over time to have either very light fur or very dark fur, leaving no animals with medium-colored fur. This process is called
- A. stabilizing selection.
  - B. speciation.
  - C. discretionary selection.
  - D. disruptive selection
76. What is the name of the process through which scientists create genetically identical organisms?
- A. sequencing
  - B. cloning
  - C. recombining
  - D. splicing
77. In a biochemistry laboratory, a highly volatile chemical is to be mixed with another chemical to form a new compound solution. Which of these precautions is the **most** important to follow during this experiment?
- A. wearing eye goggles
  - B. protecting your clothes with an apron
  - C. covering your hair with a cap
  - D. using equal-sized glass beakers

Name:

Date:

78. The cells of a dog's tail contain 78 chromosomes. The spermatozoa of a dog contain
- A. 39 chromosomes.
  - B. 78 chromosomes.
  - C. 117 chromosomes.
  - D. 156 chromosomes.
79. Which of the following occurs first when a cell undergoes mitosis?
- A. Spindle fibers attached to the centromeres.
  - B. The cytoplasm divides.
  - C. Chromatin coils into chromosomes.
  - D. Sister chromatids separate.
80. During the process of cellular respiration, energy is obtained from
- A. glucose.
  - B. RNA.
  - C. catalysts.
  - D. lipids.
81. A student wants to study the effect of chlorine on the growth of bacteria. The student sets up four test tubes and adds 20-mL of sterile beef broth to each test tube. The student adds 5-mL of chlorine solution to test tube A, 10-mL of chlorine solution to test tube B, 15-mL of chlorine solution to test tube C, and nothing to test tube D. The student then plugs the test tubes with cotton. Every day for a week, the student checks each test tube for signs of bacterial growth.
- What role does test tube D play in this experiment?
- A. variable
  - B. hypothesis
  - C. catalyst
  - D. control

82. Brianna wanted to investigate the effect of plant food on the growth of geranium plants. She designed an experiment using two groups of plants. She gave plant food to one group of five healthy geranium plants being grown in potting soil. She added nothing to the other group of five healthy geranium plants being grown in sandy soil. Both groups of plants received the same amount of light and water. After two weeks, the plants given plant food were taller than the plants not given plant food. Brianna concluded that plant food makes geranium plants grow more quickly.

Why is Brianna's conclusion invalid?

- A. One group of plants was already taller and healthier than the other when she began the experiment.
  - B. She planted one group of plants in potting soil and the other in sandy soil.
  - C. She gave both groups of plants equal amounts of water.
  - D. Both groups of plants received the same amount of light.
83. Martin wants to find some general information about DNA. Where would be the **best** place for him to start?
- A. an encyclopedia
  - B. a science periodical
  - C. a thesaurus
  - D. a world almanac
84. What is the field of biology that specializes in the study of plants called?
- A. anatomy
  - B. botany
  - C. ecology
  - D. physiology

Name:

Date:

85.

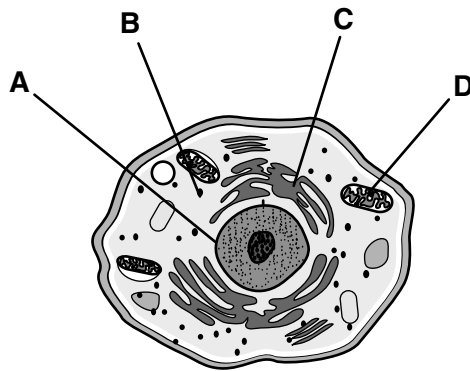

Which organelle shown in the diagram above provides energy for the cell by performing aerobic respiration?

- A. A
  - B. B
  - C. C
  - D. D
86. In the kidneys, the concentration of water is higher in the renal tubules than it is in the blood. The absorption of water from the blood into the renal tubules is achieved through
- A. active transport.
  - B. diffusion.
  - C. osmosis.
  - D. passive transport.
87. Most chemical reactions that occur in living organisms require the presence of one or more enzymes. Based on their chemical structures and properties, enzymes would be classified as
- A. carbohydrates.
  - B. lipids.
  - C. nucleic acids.
  - D. proteins.

88.

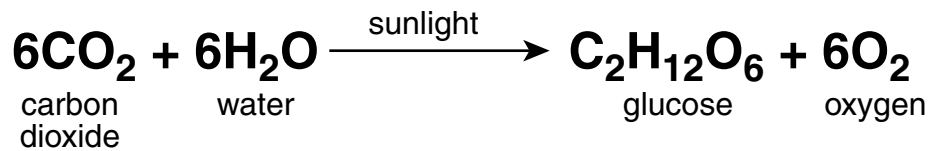

The chemical equation above lists the reactants, products, and energy requirements for what process?

- A. fermentation
  - B. photosynthesis
  - C. protein synthesis
  - D. respiration
89. In the lab, a molecular biologist created artificial messenger RNA containing only uracil nucleotides. She then added the artificial messenger RNA to a mixture of ribosomes, amino acids, transfer RNA, and ATP. The polypeptides synthesized by this mixture consisted of chains containing only one amino acid, phenylalanine.

Based on these results, what might the molecular biologist conclude?

- A. The sequence U-U-U in DNA is the genetic code for the amino acid phenylalanine.
  - B. The sequence U-U-U in messenger RNA is the code for the amino acid phenylalanine.
  - C. Protein synthesis can only occur in living cells.
  - D. Protein synthesis can only occur in the presence of an endoplasmic reticulum.
90. Normally, each cell of a leopard frog contains 26 chromosomes. However, some cells in the leopard frog may contain only 13 chromosomes as a result of
- A. cleavage.
  - B. crossing over.
  - C. meiosis.
  - D. mitosis.



94. To prevent milk from spoiling too quickly, it is heated to a high enough temperature to destroy harmful bacteria without changing the composition or flavor of the milk. What is this process called?
- A. detoxification
  - B. genetic engineering
  - C. pasteurization
  - D. purification
95. African sleeping sickness is caused by a protozoan that is transmitted from one human being to another via the tsetse fly, a blood-sucking insect found only in Africa. The disease derives its name from the fact that, although the protozoan starts as a parasite in the blood, in the later stages of the infection it can invade the
- A. brain and spinal cord.
  - B. intestinal tract.
  - C. liver.
  - D. heart and lungs.
96. Which of the following organisms are heterotrophs?
- A. blue-green algae
  - B. ferns
  - C. mushrooms
  - D. pine trees
97. Mosses generally grow on the north side of trees in order to avoid direct sunlight. This is because mosses lack
- A. chlorophyll.
  - B. flowers.
  - C. seeds.
  - D. vascular tissue.
98. In angiosperms, nectar and brightly colored flowers attract insects. This increases the likelihood that what process will occur?
- A. fertilization
  - B. germination
  - C. pollination
  - D. seed dispersal
99. Farmers often introduce ladybugs into crops as predators to reduce the number of aphids feeding on their plants. This is an example of what process?
- A. biological control of insect pests
  - B. chemical control of insect pests
  - C. conservation of natural resources
  - D. preservation of endangered species
100. What characterizes reproduction in reptiles?
- A. internal fertilization and internal development
  - B. internal fertilization and external development
  - C. external fertilization and internal development
  - D. external fertilization and external development